

# CARPIGIANI

## UC-711G/P

Single Flavor  
Counter Model



Carpigiani's UC-711 will dispense a single flavor of your favorite frozen dessert. Designed for low to medium production, its compact size will easily fit on your counter. Choose the simple gravity version to begin making high profits or select the pump model for increased performance and higher profits. Gravity and pump models combine the latest technology for easy, efficient operation.

### Features Include:

- Touchpad controls provide fingertip command of machine functions
- Low mix indicator light with audible signal
- Gravity and pump mix feed systems offer simple operation and smoother, creamier product
- Standby/energy conservation mode reduces cost of operation during idle periods
- Cylinder design optimizes refrigeration efficiency
- Self-monitoring system minimizes costly errors
- Built-in memory stores information to facilitate repairs

# CARPIGIANI

Carpigiani-USA manufactures a complete line of ice cream production equipment: Batch Freezers, Soft Serve Freezers, Yogurt Freezers, Slush Freezers, Milk Shake Machines, Whipped Topping Dispensers, Granita Machines, Frozen Custard Freezers, Mix Processing Equipment and Display Cabinets...

*Something for everyone!*

# SPECIFICATIONS

## MODEL UC-711G/P



Single flavor counter model. Designed for low to medium volume requirements. Gravity or pump.

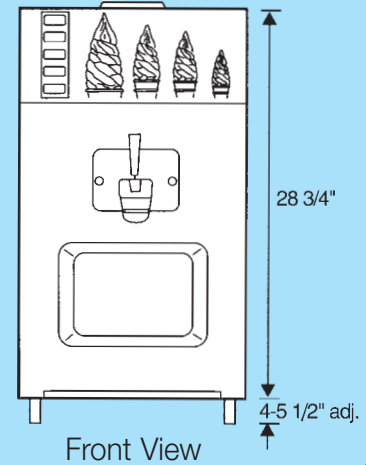
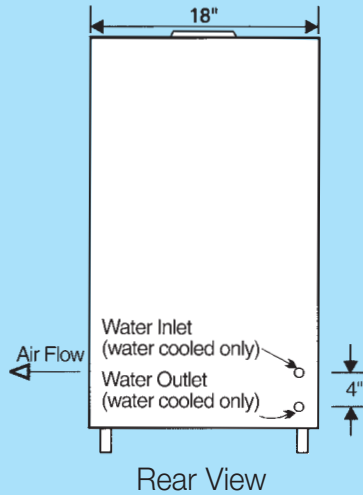
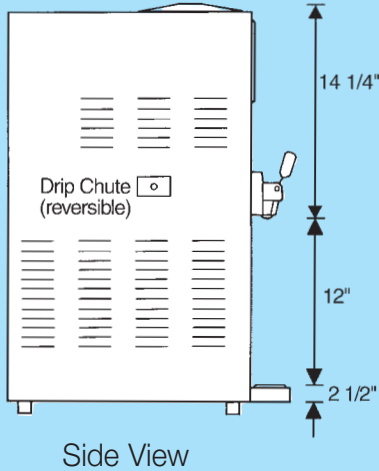
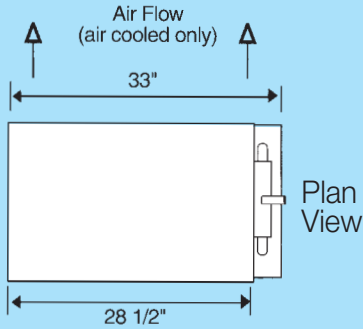

### Model UC-711 G/P Description:

Overrun Range \_\_\_\_\_ 20% to 40% (Gravity Fed)  
 Overrun Range \_\_\_\_\_ 40% to 80% (Pump Fed)  
 Mix Tank Capacity \_\_\_\_\_ 10 qts. each  
 Mix Tank Refrigeration Control \_\_\_\_\_ Electronic  
 Cylinder Refrigeration Control \_\_\_\_\_ Hard-O-Tronic  
 Cylinder Type \_\_\_\_\_ Helicoidal Path  
 Beater Construction \_\_\_\_\_ Stainless Steel  
 Beater Drive Motor \_\_\_\_\_ 0.75 H.P.  
 Compressor Motor \_\_\_\_\_ 1.0 H.P.  
 Water Connections \_\_\_\_\_ 1/2" M.T.P.  
 Condenser Cooling \_\_\_\_\_ Air or Water  
 Refrigerant Type \_\_\_\_\_ R-404A  
 Frame Type \_\_\_\_\_ Heavy duty welded steel  
 Outer Panels \_\_\_\_\_ Stainless Steel front  
 \_\_\_\_\_ Coated Aluminum sides and rear

Width \_\_\_\_\_ 18 inches (458 mm)  
 Depth \_\_\_\_\_ 33 inches (839 mm)  
 Height (w/o legs) \_\_\_\_\_ 28.75 inches (730 mm)  
 Net Weight (w/o accessories) \_\_\_\_\_ 218 lbs. (99 kg)  
 Gross Weight (w/o accessories) \_\_\_\_\_ 283 lbs. (129 kg)

### Electrical Requirements

Voltage Single Phase, 60 Cycle \_\_\_\_\_ 208/230 V  
 Fuse/Breaker Size \_\_\_\_\_ 20 Amp Max.  
 Nema # \_\_\_\_\_ L15-30

### Optional Accessories

- Mix Tank Wash kit
- Self Service Kit (handle closing device)
- Adjustable Legs



Distributed by:  
 GTI Designs  
 35 Trade Zone Court  
 Ronkonkoma, NY 11779

Tel: 800 896-4484  
 Fax: 631 981-3509  
 info@gtidesigns.com  
 www.gtidesigns.com

All technical data, pictures, and drawings contained in this document are not binding on the manufacturer, nor can the manufacturer be held liable for any modification of the machine in part or completely.