

# CARPIGIANI

## UC-1131 G/P

### Double Flavor Twist Counter Model



State-of-the-art design and technology makes this soft serve both simple and efficient to operate. Dispense two individual flavors or a combination twist of your favorite frozen dessert. Choose a simple gravity model to begin your profit opportunity or select a pump model for greater performance and profits.

#### Features Include:

- Touchpad controls provide fingertip command of machine functions
- Low mix indicator light with audible signal
- Gravity and pump mix feed systems offer simple operation and smoother, creamier product
- Standby/energy conservation mode reduces cost of operation during idle periods
- Cylinder design optimizes refrigeration efficiency
- Self-monitoring system minimizes costly errors
- Built-in memory stores information to facilitate repairs

# CARPIGIANI

Carpigiani-USA manufactures a complete line of ice cream production equipment: Batch Freezers, Soft Serve Freezers, Yogurt Freezers, Slush Freezers, Milk Shake Machines, Whipped Topping Dispensers, Granita Machines, Frozen Custard Freezers, Mix Processing Equipment and Display Cabinets...

*Something for everyone!*

# SPECIFICATIONS

## MODEL UC-1131 G/P



Two flavor "twist" counter model. Designed for low to medium volume requirements. Gravity or pump.

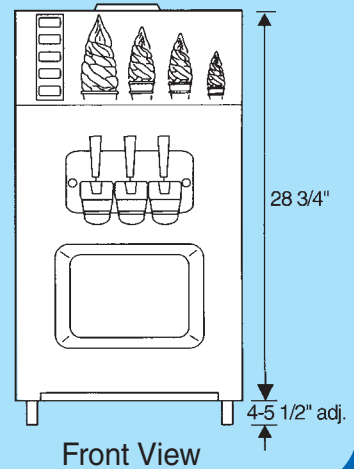
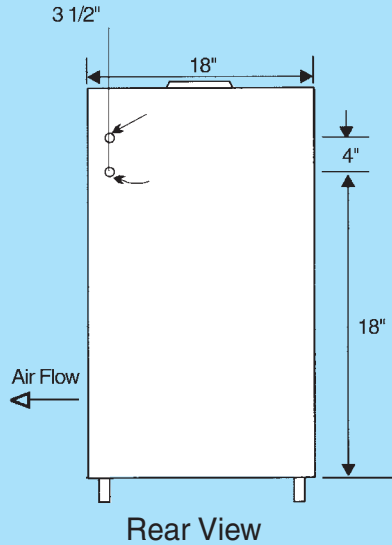
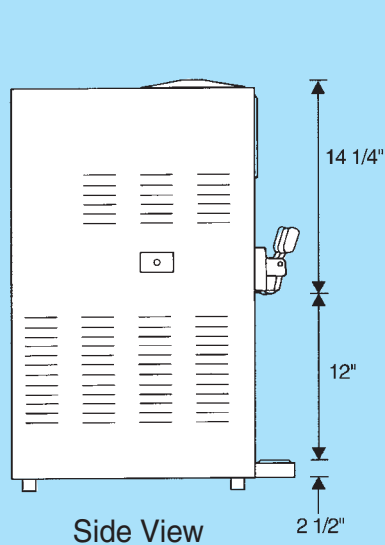
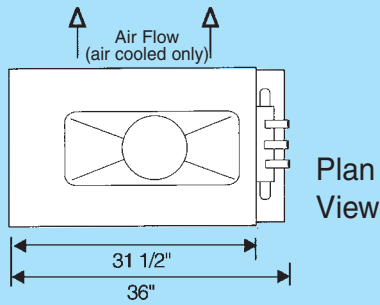

### Model UC-1131 G/P Description:

Overrun Range \_\_\_\_\_ 20% to 40% (Gravity Fed)  
 Overrun Range \_\_\_\_\_ 40% to 80% (Pump Fed)  
 Mix Tank Capacity \_\_\_\_\_ 8 qts. each  
 Mix Tank Refrigeration Control \_\_\_\_\_ Electronic  
 Cylinder Refrigeration Control \_\_\_\_\_ Hard-O-Tronic  
 Cylinder Type \_\_\_\_\_ Helicoidal Path  
 Beater Construction \_\_\_\_\_ Stainless Steel  
 Beater Drive Motor \_\_\_\_\_ 1.8 H.P.  
 Compressor Motor \_\_\_\_\_ 2.0 H.P.  
 Water Connections \_\_\_\_\_ 1/2" M.P.T.  
 Condenser Cooling \_\_\_\_\_ Air or Water  
 Refrigerant Type \_\_\_\_\_ R-404A  
 Frame Type \_\_\_\_\_ Heavy Duty Welded Steel  
 Outer Panels \_\_\_\_\_ Stainless Steel Front  
 \_\_\_\_\_ Coated Aluminum Sides and Rear  
 Width \_\_\_\_\_ 18 inches (458 mm)  
 Depth \_\_\_\_\_ 36 inches (839 mm)

Height (w/o legs) \_\_\_\_\_ 28.75 inches (730 mm)  
 Net Weight (w/o accessories) \_\_\_\_\_ 320 lbs. (145 kg)  
 Gross Weight (w/o accessories) \_\_\_\_\_ 385 lbs. (175 kg)

### Electrical Requirements

Single Phase, 60 Hz \_\_\_\_\_ 208 - 230 V  
 Max Breaker / Fuse size \_\_\_\_\_ 30 Amps  
 Running Amps \_\_\_\_\_ 25 Amps  
 Nema # \_\_\_\_\_ L15-30

### Optional Accessories

- Mix Tank Wash kit
- Self Service Kit (handle closing device)
- Adjustable Legs



Distributed by:  
 GTI Designs  
 35 Trade Zone Court  
 Ronkonkoma, NY 11779

Tel: 800 896-4484  
 Fax: 631 981-3509  
 info@gtidesigns.com  
 www.gtidesigns.com

All technical data, pictures, and drawings contained in this document are not binding on the manufacturer, nor can the manufacturer be held liable for any modification of the machine in part or completely.