

CARPIGIANI

LB-502, LB-502G, LB-502G *Tru-2*

Single and Two Speed Batch Freezer – Floor Model



Ice cream made easy! Carpigiani has enjoyed a reputation for superior quality; now it has also built a reputation for simplicity. Our fully automatic freezer with touchpad controls is simple to operate. A novice will achieve great results on the first try, yet the flexibility of the controls will satisfy even the most demanding expert. No other manufacturer offers this combination of quality and simplicity. In no time you will begin making great premium and gourmet ice cream, gelato, sorbet, water ice and much more.

Features Include:

- Automatic operation with electronic consistency control
- Unique cylinder design results in faster production and smoother finished product
- Audible alarm signals when product is ready to extract
- Cam door latch provides quick interior access
- Maximum extraction results in minimal flavor overlap
- Built-in faucet with flex hose makes cleaning fast and easy
- “G” model recommended for low overrun gourmet products, including gelato, sorbets and frozen custard
- Our new *Tru-2* provides the greatest flexibility in the industry to create the widest range of products

CARPIGIANI

Carpigiani-USA manufactures a complete line of ice cream production equipment: Batch Freezers, Soft Serve Freezers, Yogurt Freezers, Slush Freezers, Milk Shake Machines, Whipped Topping Dispensers, Granita Machines, Frozen Custard Freezers, Mix Processing Equipment and Display Cabinets...

Something for everyone!

SPECIFICATIONS

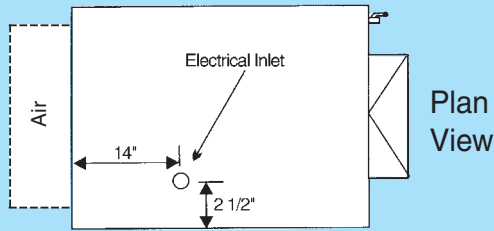

Single/two speed floor model. Designed for medium to high volume requirements.

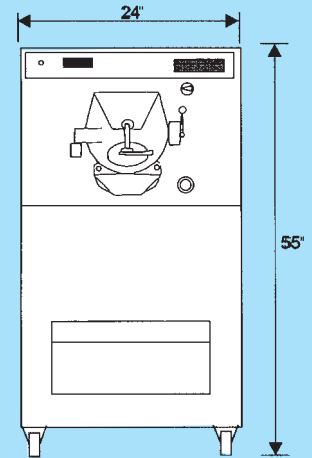
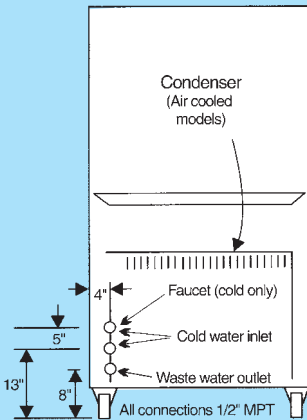
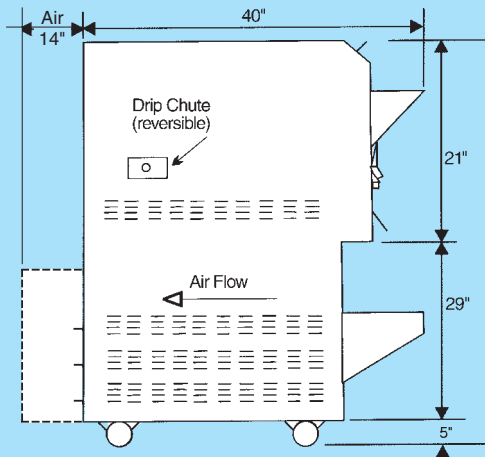

Models LB-502, 502G & 502G Tru-2 Description:

Cylinder Capacity (w/beater)	20 Qts
Cylinder Refrig. Control System	Electronic
Cylinder Type	Helicoidal Path
Compressor Motor	3 H.P.
Water Connections	1/2" MPT
Condenser Cooling	Air or Water
Refrigerant Type	R-404A
Frame Type	Floor Model
Frame Construction	Welded Steel
Outer Panels	Stainless Steel
Faucet with Flex Hose	Standard
Width	24 inches (610 mm)
Depth	40 inches* (1016 mm)
Height (w/casters)	55 inches (1400 mm)
5" Casters	Standard

LB-502

Beater Drive Motor	3 H.P.
Beater Design	Unibody w/Delrin Blades
* Water Cooled	

Model LB-502 (continued)

Net Weight	635 lbs. (289 kg)
Gross Weight	693 lbs. (315 kg)
Single Phase, 60 Hz	208/230 V
Max Breaker / Fuse size	40 Amps
Running Amps	36 Amps
Three Phase, 60 Hz	208/230 V
Max Breaker / Fuse size	30 Amps
Running Amps	23 Amps
Number of Feeders	1
Nema #	L15-30

Models LB-502G & 502G Tru-2

Beater Drive Motor	3.75 / 7.5 H.P.
Beater Design	Unibody w/Replaceable Blades
Net Weight	693 lbs. (315 kg)
Gross Weight	770 lbs. (350 kg)
Three Phase, 60 Hz	208/230 V
Max Breaker / Fuse size	40 Amps
Running Amps	35 Amps
Number of Feeders	1
Nema #	L15-30



Distributed by:
GTI Designs
35 Trade Zone Court
Ronkonkoma, NY 11779

Tel: 800 896-4484
Fax: 631 981-3509
info@gtidesigns.com
www.gtidesigns.com

All technical data, pictures, and drawings contained in this document are not binding on the manufacturer, nor can the manufacturer be held liable for any modification of the machine in part or completely.